

# Rakks

## EH In-Wall Counter Support Bracket

### EH-1209FM

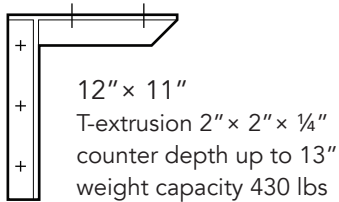

### EH-1212FM

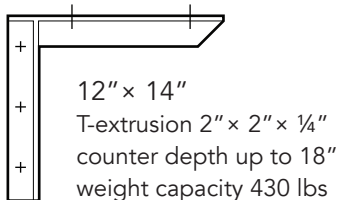

### EH-1818FM

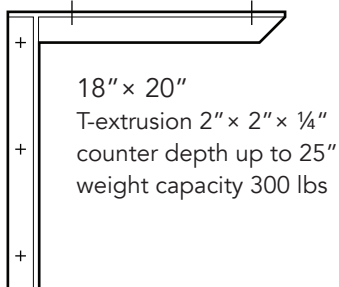

### EH-1824FM

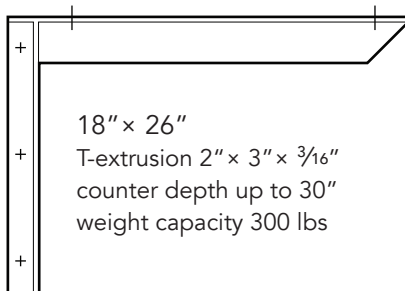

Weight capacity is based on evenly distributed static loads

### Parts included:



Heavy-duty aluminum Rakks EH in-wall (flush) counter support brackets  
Classic mitered or rounded edges

### Additionally, you will need:



2-2 1/2" x 1/4" carriage bolts (preferred) for 1 1/2" wide studs



#14 x 2 1/2" screws and washers for mounting to wall studs



Construction adhesive or screws for countertop surface mounting according to manufacturer's recommendation



Rakks In-Wall Counter Support Faceplate (optional) to cover rough cuts in wall surface

Measuring tape  
Pencil or painter's tape  
Level

Wrench for carriage bolts  
Drill driver + drill bit

### Acceptable mounting applications:

Wood studs  
Double studs  
Metal studs with wood blocking

Three (3) secured carriage bolts (preferred) or screws per bracket for up to 48" bracket spacing.

For other mounting surfaces, contact your Rakks representative.

## EH In-Wall Counter Support Bracket

**In-wall counter support brackets** are mounted flush to the right side of the **wall stud**, unless you purchased left-mounting brackets for a stud that cannot accommodate a right-side installation.

### 1

### Mark out the locations of your counter support brackets.

Measure up from the floor to the desired underside of the countertop. Mark the location on the front and side of the wall stud.

Hold the bracket in place on the side of the wall stud at the countertop mark. The horizontal arm should be level and the vertical support should be plumb and flush with the front of the wall stud.

Mark the top mounting-hole location on the wall stud with a pencil.

**Note:** If the wall is not perfectly plumb, it is important to recess the counter bracket at either top or bottom as needed, to ensure that the countertop is level and the drywall will sit flat against the stud.

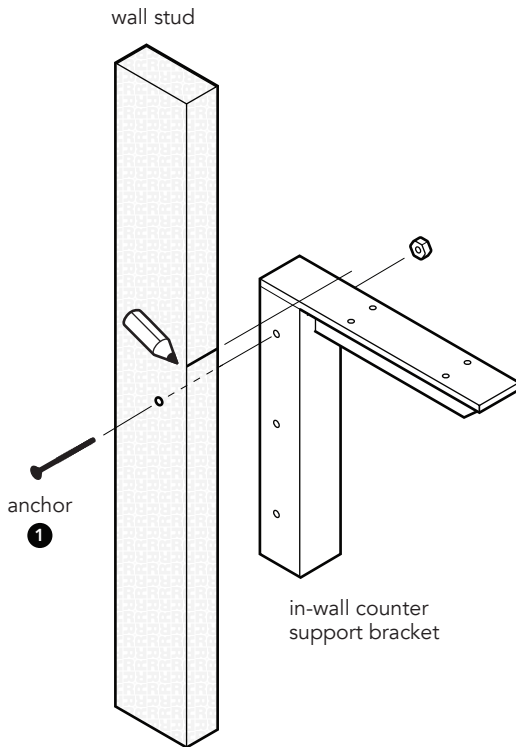

### 2

### Secure the brackets.

**If you opted for carriage bolts:** Use a  $\frac{1}{4}$ " or  $\frac{5}{16}$ " bit to drill through the wall stud at the top hole location. Install the top carriage bolt until snug but not tight.

**Or if using screws:** Use a  $\frac{5}{32}$ " bit to drill a pilot hole at the top hole location. Install the top #14 x 2 $\frac{1}{2}$ " screw until snug but not tight.

Level the horizontal support of the counter bracket, then mark the two remaining hole locations on the stud. Pivot the counter bracket out of the way while you drill the other two pilot holes.

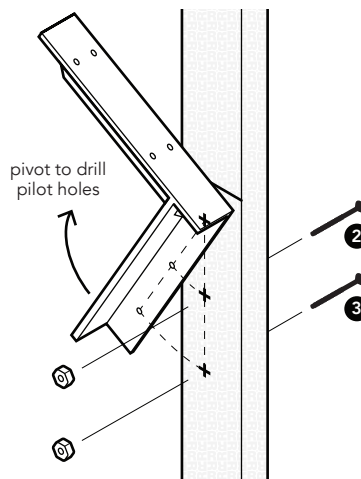

Install the remaining **anchors** and tighten all three until the counter bracket is secure. Carriage bolts should be seated into the wall stud properly.

Measure over with a level to the next counter bracket location and repeat the steps above.

### 3

### Apply finished wall surface.

You are now ready to install the drywall or other finished wall surface.

If you opted to use a Rakks faceplate it will cover rough cuts in the wall surface.

If not, you will need to take careful measurements and mark where each horizontal support will protrude through the wall surface. Cut out the T-shape of the bracket.